

技术参数附件:

1 废料斗:

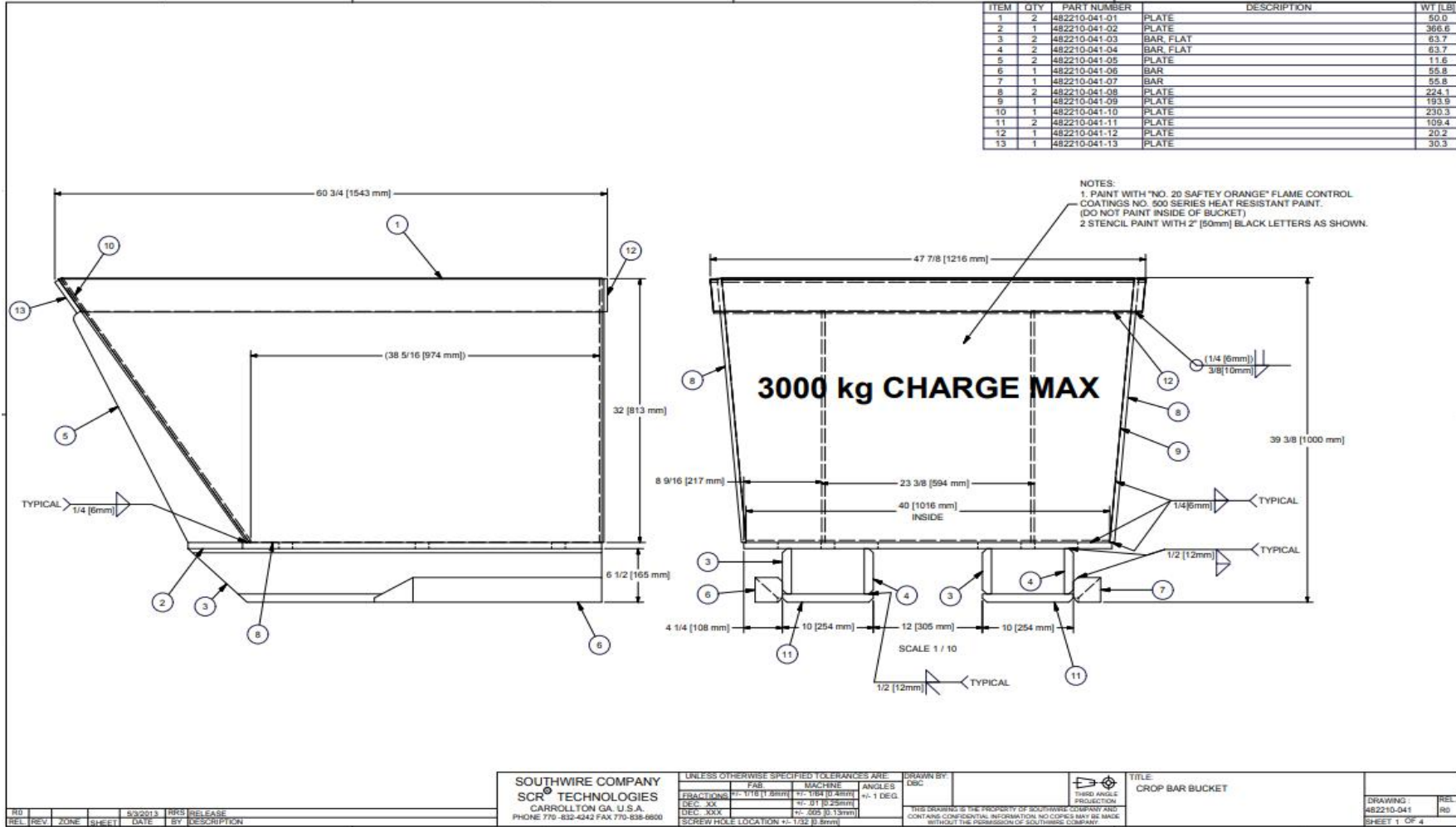

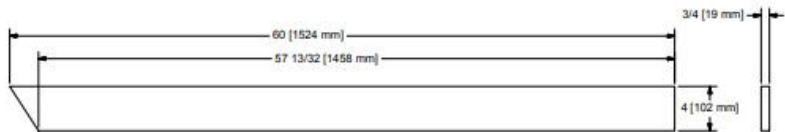

SCALE 1 / 10

P/N: 482210-041-01  
MATL: HRS

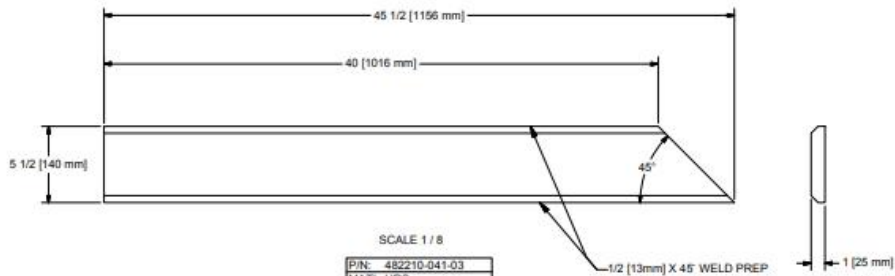

SCALE 1 / 8

P/N: 482210-041-03  
MATL: HRS

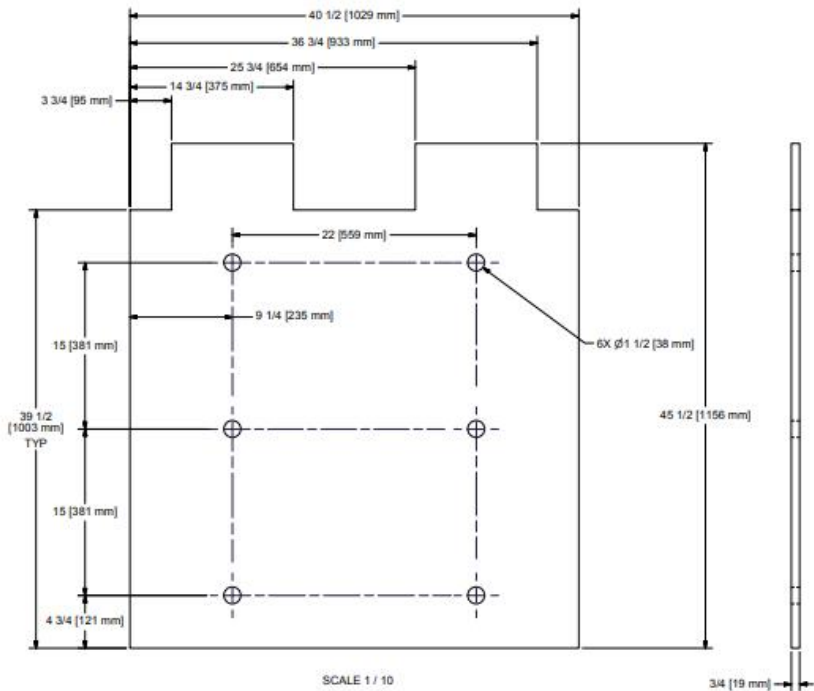

SCALE 1 / 10

P/N: 482210-041-02  
MATL: HRS

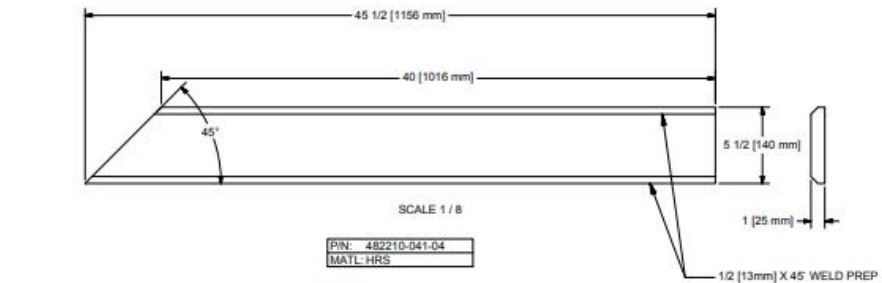

SCALE 1 / 8

P/N: 482210-041-04  
MATL: HRS

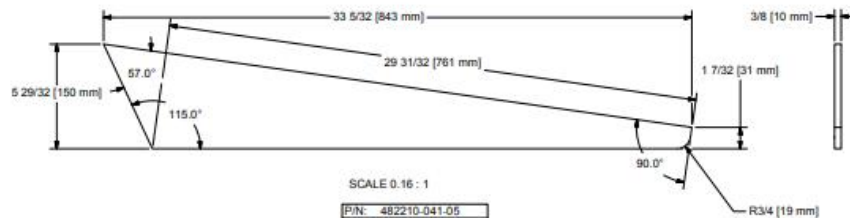

SCALE 0.16 : 1

P/N: 482210-041-05  
MATL: HRS

SOUTHWIRE COMPANY  
SCR<sup>®</sup> TECHNOLOGIES  
CARROLLTON GA, U.S.A.  
PHONE 770-832-4242 FAX 770-838-8800

| UNLESS OTHERWISE SPECIFIED TOLERANCES ARE: |                |                |          |
|--|----------------|----------------|----------|
| FRACTIONS                                  | FAB.           | MACHINE        | ANGLES   |
| DEC. .XX                                   | ±.118 [1.2mm]  | ±.118 [0.4mm]  | ±.1 DEG. |
| DEC. .XXX                                  | ±.01 [0.25mm]  | ±.01 [0.25mm]  |          |
| DEC. .XXX                                  | ±.005 [0.13mm] | ±.005 [0.13mm] |          |
| SCREW HOLE LOCATION                        | ±.132 [3.2mm]  |                |          |

DRAWN BY: DEC  
THIS DRAWING IS THE PROPERTY OF SOUTHWIRE COMPANY AND CONTAINS CONFIDENTIAL INFORMATION. NO COPIES MAY BE MADE WITHOUT THE PERMISSION OF SOUTHWIRE COMPANY.



TITLE  
CROP BAR BUCKET

DRAWING: 482210-041  
REL: RD  
SHEET 2 OF 4

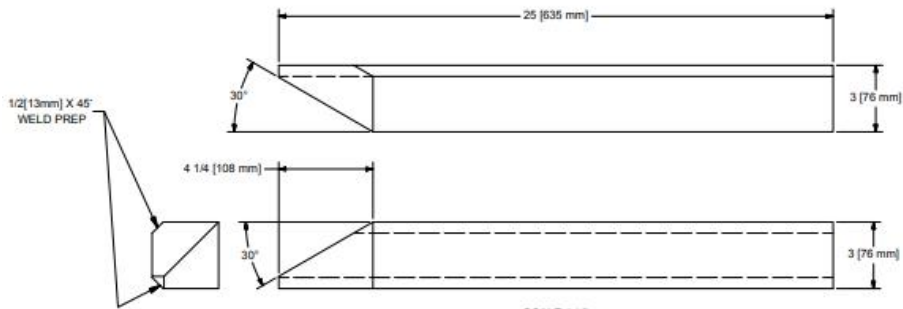

SCALE 1 / 5

P/N: 482210-041-06  
MATERIAL: HRS

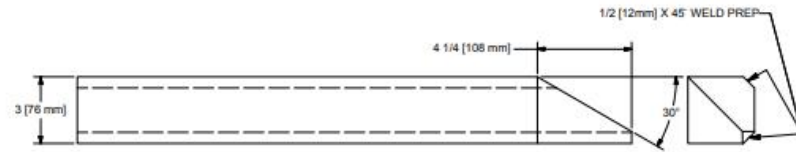

SCALE 1 / 5

P/N: 482210-041-07  
MATERIAL: HRS

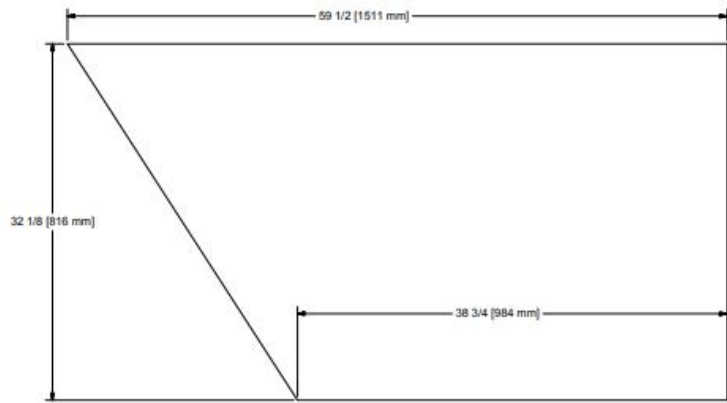

SCALE 1 / 10

P/N: 482210-041-08  
MATERIAL: HRS

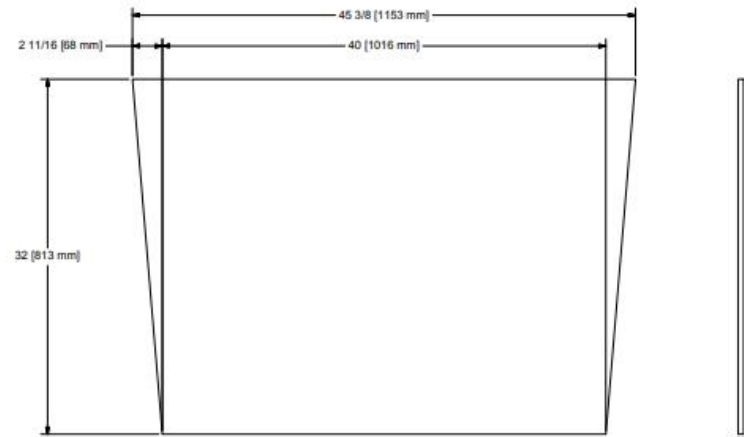

SCALE 1 / 10

P/N: 482210-041-09  
MATERIAL: HRS

|    |     |      |       |         |     |             |
|----|-----|------|-------|---------|-----|-------------|
| RD | REV | ZONE | SHEET | DATE    | BY  | DESCRIPTION |
|    |     |      |       | 9/20/13 | RR3 | RELEASE     |

**SOUTHWIRE COMPANY**  
**SCR® TECHNOLOGIES**  
CARROLLTON GA. U.S.A.  
PHONE 770-832-4242 FAX 770-838-8800

|  |               |               |          |
|--|---------------|---------------|----------|
| UNLESS OTHERWISE SPECIFIED TOLERANCES ARE: |               |               |          |
| FRACTIONS                                  | FAB           | MACHINE       | ANGLES   |
| DEC .XX                                    | ±.178 [4.5mm] | ±.178 [4.5mm] | ±.1 DEG. |
| DEC .XXX                                   | ±.01 [0.25mm] | ±.01 [0.25mm] |          |
| SCREW HOLE LOCATION                        | ±.132 [3.3mm] |               |          |

DRAWN BY: DBC  
THIRD ANGLE PROJECTION  
THIS DRAWING IS THE PROPERTY OF SOUTHWIRE COMPANY AND CONTAINS CONFIDENTIAL INFORMATION. NO COPIES MAY BE MADE WITHOUT THE PERMISSION OF SOUTHWIRE COMPANY.

TITLE: CROP BAR BUCKET

|            |      |
|------------|------|
| DRAWING:   | REL  |
| 482210-041 | RD   |
| SHEET 3    | OF 4 |

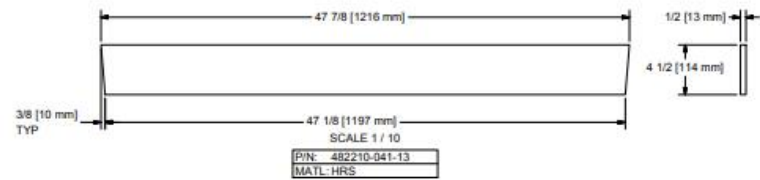
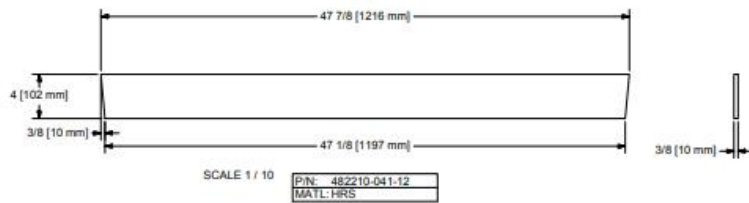
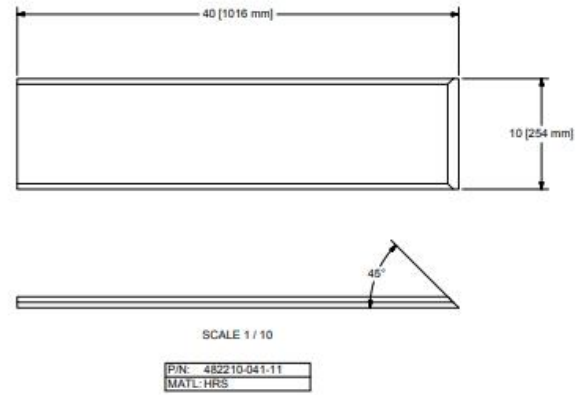
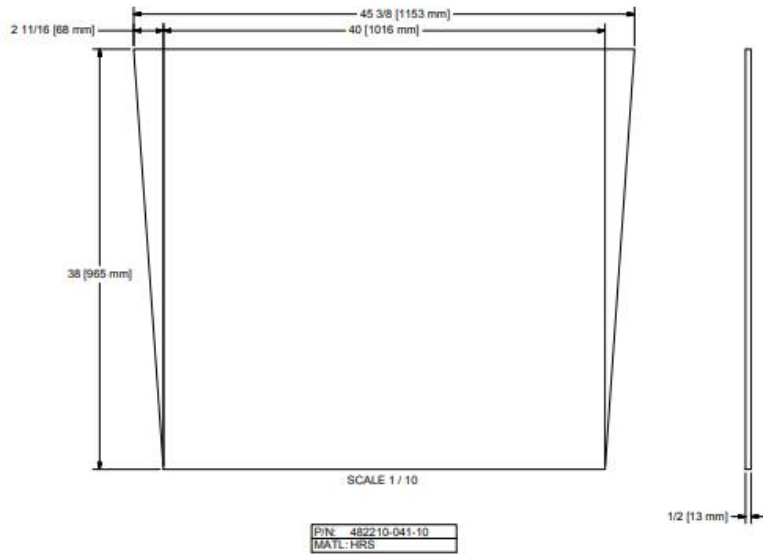

SOUTHWIRE COMPANY  
SCR<sup>®</sup> TECHNOLOGIES  
CARROLLTON GA, U.S.A.  
PHONE 770-832-4242 FAX 770-838-6500

| UNLESS OTHERWISE SPECIFIED TOLERANCES ARE: |                |                |          |
|--|----------------|----------------|----------|
| FRACTIONS                                  | FAB            | MACHINE        | ANGLES   |
| DEC. XX                                    | ±.118 [1.88mm] | ±.104 [0.85mm] | ±.1 DEG. |
| DEC. XXX                                   | ±.01 [0.25mm]  | ±.003 [0.13mm] |          |
| SCREW HOLE LOCATION ±.132 [3.3mm]          |                |                |          |

DRAWN BY: DBC  
THIRD ANGLE PROJECTION  
THIS DRAWING IS THE PROPERTY OF SOUTHWIRE COMPANY AND CONTAINS CONFIDENTIAL INFORMATION. NO COPIES MAY BE MADE WITHOUT THE PERMISSION OF SOUTHWIRE COMPANY.

TITLE  
CROP BAR BUCKET

|                        |            |
|------------------------|------------|
| DRAWING:<br>482210-041 | REL.<br>R0 |
| SHEET 4 OF 4           |            |

## 2、渣池溜嘴

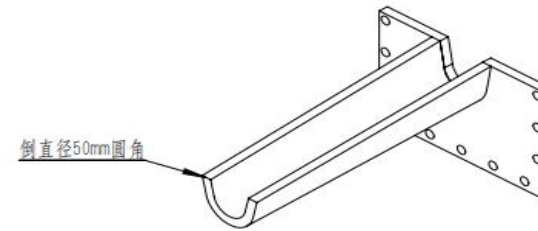
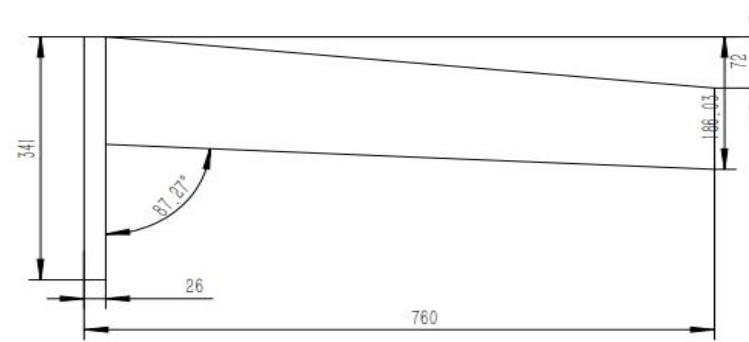
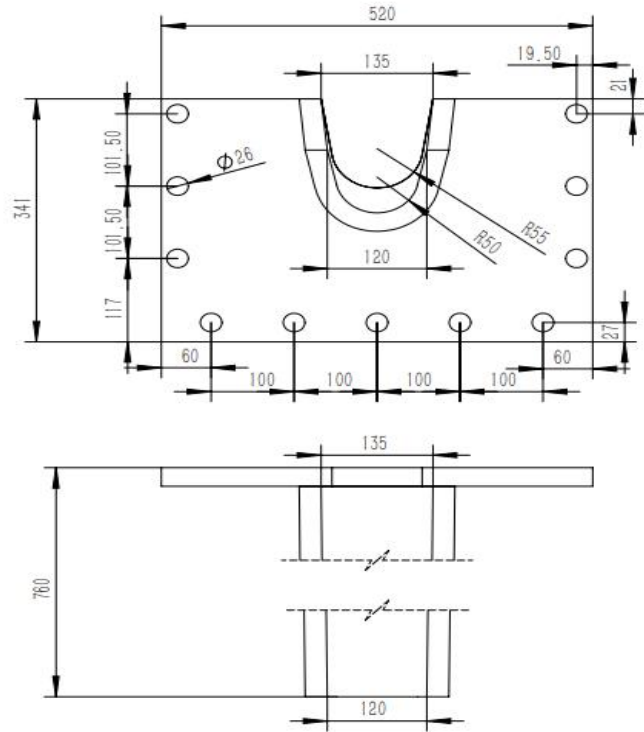

|                |     |           |                  |     |
|----------------|-----|-----------|------------------|-----|
| 制图             | 陈迪望 | 2022.7.22 | 渣池流嘴             | 比例: |
| 校核             | XXX | XXX       |                  | 材质: |
| 黄石晟祥铜业有限公司-制造部 |     |           | 图纸编号: 482240-011 |     |

### 3、撇渣槽溜嘴法兰

| ITEM | QTY | PART NUMBER   | DESCRIPTION   | WT (LB) |
|------|-----|---------------|---|---------|
| 1    | 1   | 482240-277-01 | PLATE   | 24.8    |
| 2    | 1   | 482240-277-02 | PLATE   | 36.8    |
| 3    | 2   | 482240-277-03 | PLATE   | 2.6     |
| 4    | 2   | 482240-277-04 | BAR, FLAT 1/2 X 2 X 5 7/16 (13 mm X 51 mm X 138 mm) | 1.5     |
| 5    | 1   | 482240-278-01 | PLATE   | 17.9    |

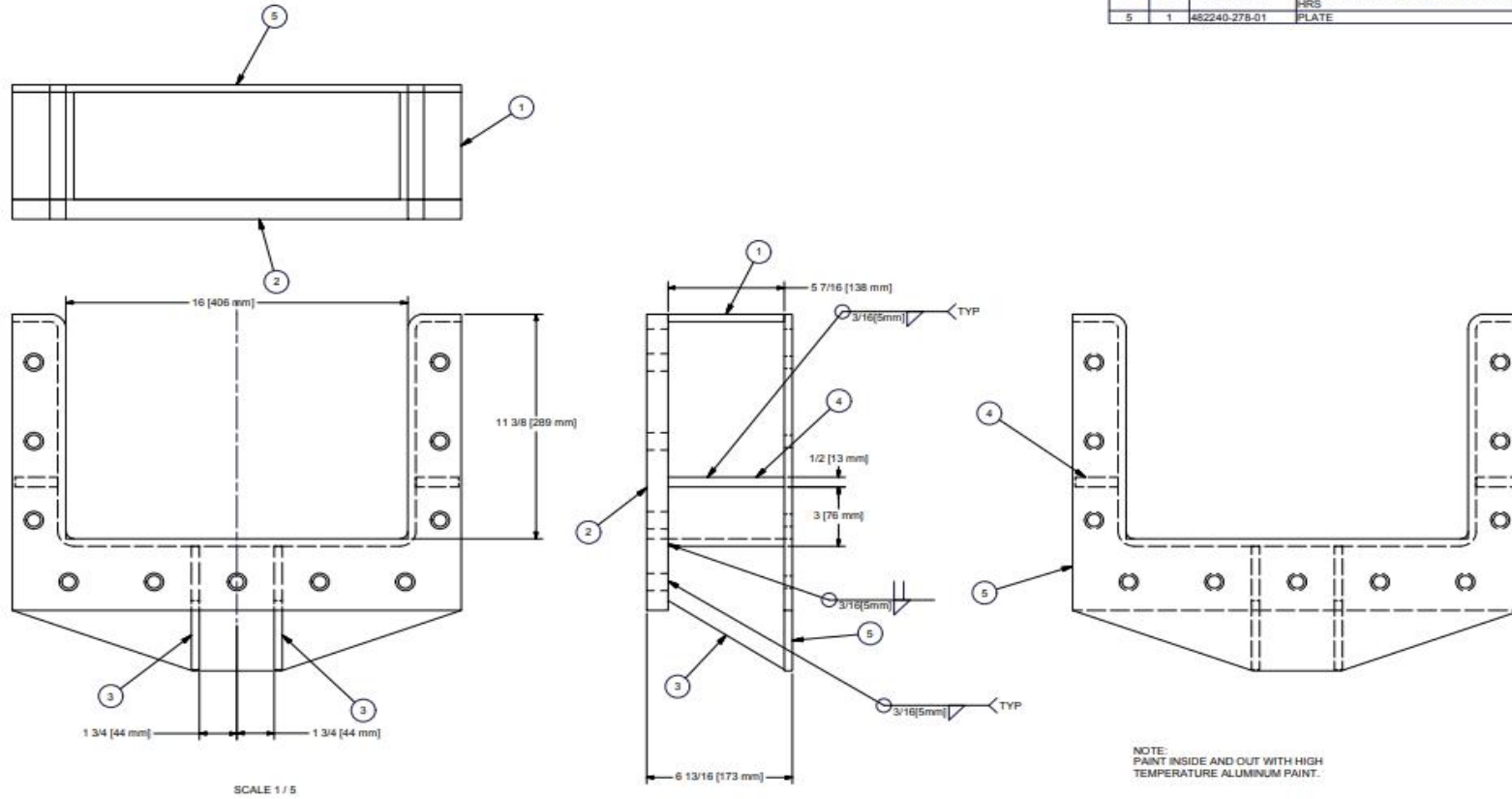

|   |     |      |       |  |    |  |  |                                      |  |  |  |
|---|-----|------|-------|--|----|--|--|--------------------------------------|--|--|--|
| SOUTH WIRE COMPANY<br>SCR <sup>®</sup> TECHNOLOGIES<br>CARROLLTON GA, U.S.A.<br>PHONE: 770-432-4242 FAX: 770-338-8200 |     |      |       | UNLESS OTHERWISE SPECIFIED TOLERANCES ARE:<br>FRACTIONS: FAB: 1/16 (1.5mm) MACHINE: 1/32 (0.4mm)<br>DEC: .XX ±.01 (0.25mm)<br>DEC: .XXX ±.005 (0.13mm)<br>SCREW HOLE LOCATION: ±.132 (3.3mm) |    | DRAWN BY: DBC<br>THIRD ANGLE PROJECTION<br>THIS DRAWING IS THE PROPERTY OF SOUTHWIRE COMPANY AND CONTAINS CONFIDENTIAL INFORMATION. NO COPIES MAY BE MADE WITHOUT THE PERMISSION OF SOUTHWIRE COMPANY. |  | TITLE: TILTING SLAG VESSEL LIP MOUNT |  | DRAWING: 482240-277<br>REL: (RD)<br>SHEET 1 OF 2 |  |
| RD  | DEV | ZONE | SHEET | DATE   | BY | DESCRIPTION  |  |                                      |  |  |  |

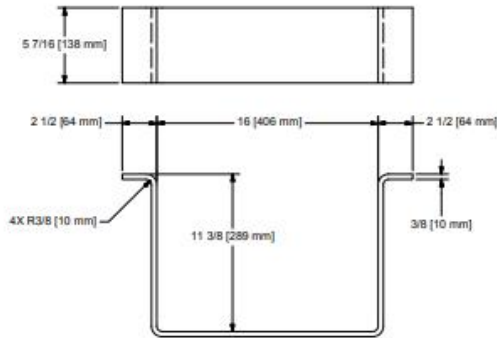

SCALE 1 / 8

PIN: 482240-277-01  
MATL: HRS

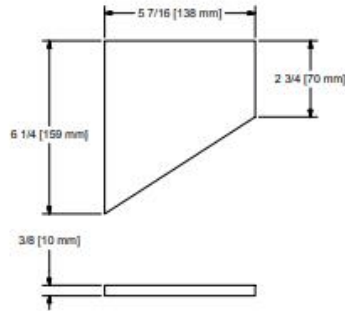

SCALE 1 / 4

PIN: 482240-277-03  
MATL: HRS

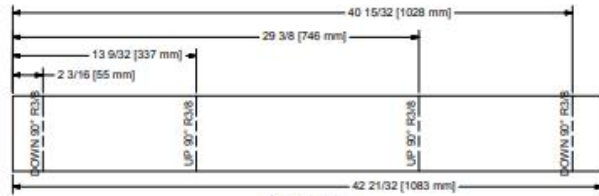

FLAT PATTERN  
SCALE 1 / 8

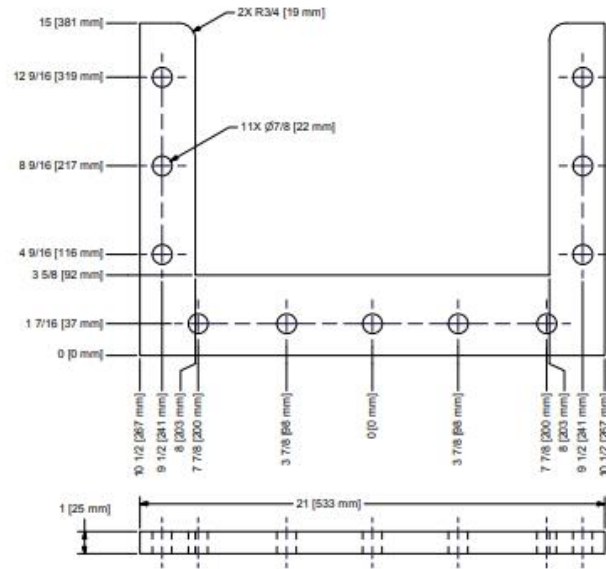

SCALE 1 / 5

PIN: 482240-277-02  
MATL: HRS

SOUTHWIRE COMPANY  
SCR<sup>®</sup> TECHNOLOGIES  
CARROLLTON GA, U.S.A.  
PHONE: 770-832-4242 FAX: 770-838-8600

| UNLESS OTHERWISE SPECIFIED TOLERANCES ARE: |                 |                                     |           |
|--|-----------------|-------------------------------------|-----------|
| FRACTIONS                                  | FAB             | MACHINE                             | ANGLES    |
| XX   | ± 1/16 (1.59mm) | ± 1/64 (0.39mm)                     | ± 1.0 DEG |
| XXX  | ± 1/32 (0.76mm) | ± .01 (0.25mm)                      |           |
|  |                 | ± .003 (0.13mm)                     |           |
|  |                 | SCREW HOLE LOCATION ± .132 (3.35mm) |           |

DRAWN BY: DBC  
THIRD ANGLE PROJECTION  
THIS DRAWING IS THE PROPERTY OF SOUTHWIRE COMPANY AND CONTAINS CONFIDENTIAL INFORMATION. NO COPIES MAY BE MADE WITHOUT THE PERMISSION OF SOUTHWIRE COMPANY.

TITLE:  
TILTING SLAG VESSEL LIP MOUNT

DRAWING: 482240-277  
REL: RO  
SHEET 2 OF 2

#### 4、上溜槽溜嘴

| ITEM | QTY | PART NUMBER  | DESCRIPTION                          | WT [LB] |
|------|-----|--------------|--------------------------------------|---------|
| 1    | 1   | 482240-251   | LAUNDER SECTION AT TAPHOLE, WELDMENT | 423     |
| 2    | 1   | 482240-252   | UPPER LAUNDER DOG LEG SECTION        | 317     |
| 3    | 3   | 482240-253   | UPPER LAUNDER SECTION                | 310     |
| 4    | 1   | 482240-255   | UPPER LAUNDER LIP ADAPTER            | 130     |
| 5    | 1   | 482240-326   | LIP SHIELD                           | 22      |
| 6    | 55  | MFHCS M20X60 | HEX BOLT, M20 X 60, DIN 933          | 0       |
| 7    | 11  | MFHCS M20X80 | HEX BOLT, M20 X 80, DIN 931          | 0       |
| 8    | 67  | NUT-M20      | HEX NUT, M20, ISO 4032               | 0       |
| 9    | 1   | PN116812     | LIP, SHORT LAUNDRER, CAST ALLOY      | 121     |

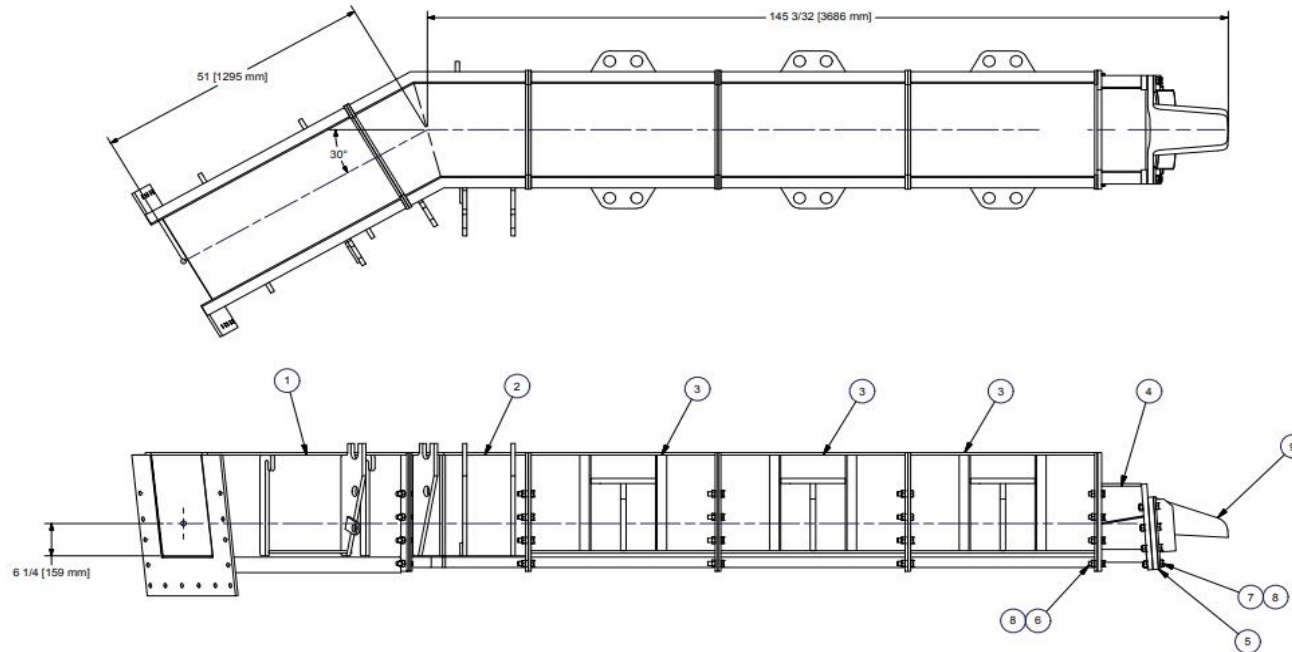

| REL | REV | ZONE | SHEET | DATE      | BY  | DESCRIPTION |
|-----|-----|------|-------|-----------|-----|-------------|
|     |     |      |       | 9/10/2013 | DBC | RELEASE     |

**SOUTHWIRE COMPANY**  
**SCR® TECHNOLOGIES**  
 CARROLLTON GA, U.S.A.  
 PHONE 770-832-4242 FAX 770-838-6600

| UNLESS OTHERWISE SPECIFIED TOLERANCES ARE: |                |         |
|--|----------------|---------|
| FAB.                                       | MACHINE        | ANGLES  |
| FRACTIONS ±1/16 [1.6mm]                    | ±1/64 [0.4mm]  | ±1 DEG. |
| DEC. XX                                    | ±.01 [0.25mm]  |         |
| DEC. XXX                                   | ±.005 [0.13mm] |         |
| SCREW HOLE LOCATION ±1/32 [0.8mm]          |                |         |

DRAWN BY:  
TRM



TITLE:  
UPPER LAUNDRER BOTTOM ASSEMBLY

THIS DRAWING IS THE PROPERTY OF SOUTHWIRE COMPANY AND  
 CONTAINS CONFIDENTIAL INFORMATION. NO COPIES MAY BE MADE  
 WITHOUT THE PERMISSION OF SOUTHWIRE COMPANY.

| DRAWING    | REL  |
|------------|------|
| 482240-003 | RO   |
| SHEET 1    | OF 1 |



### 5、上溜槽溜嘴法兰

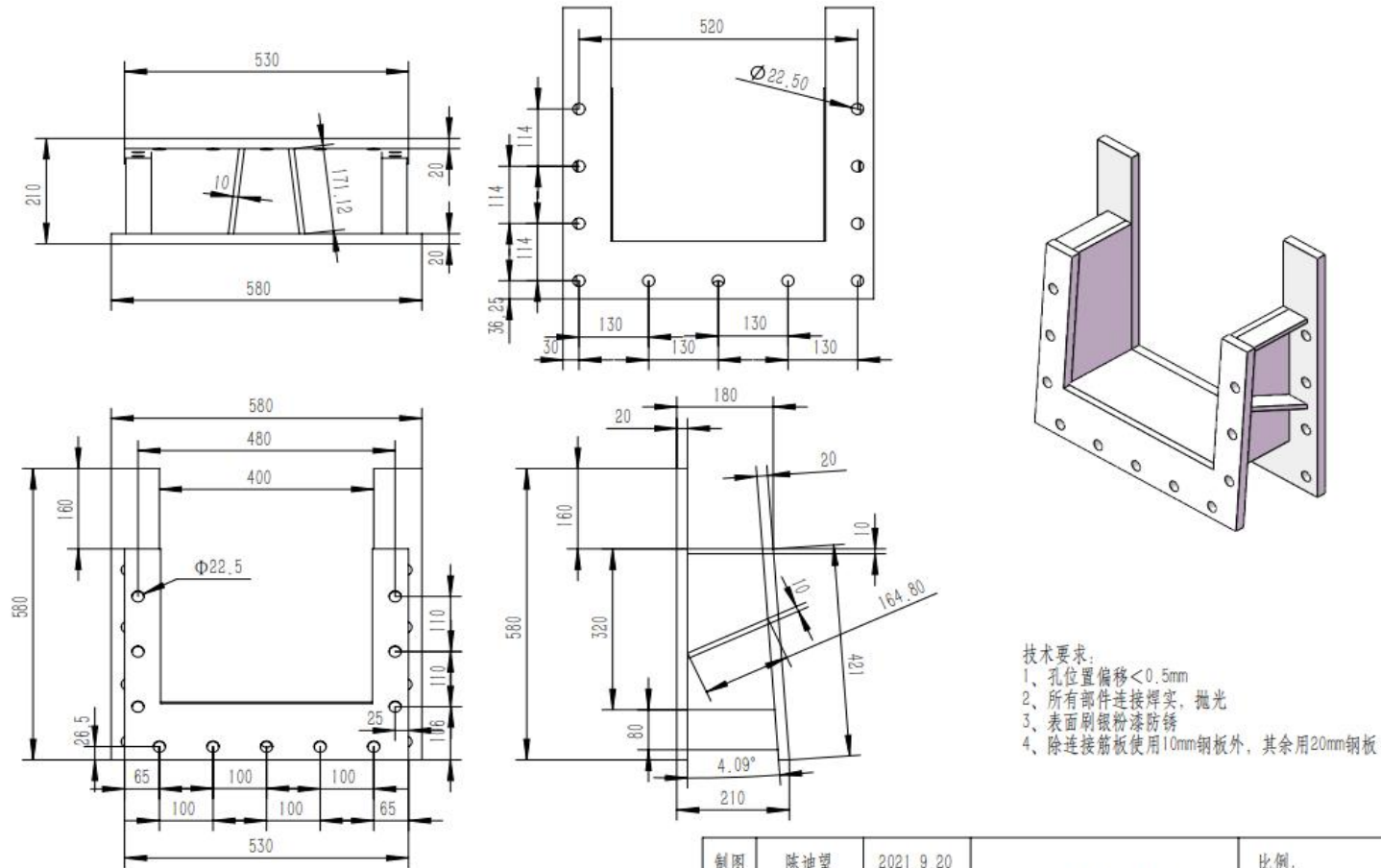

|                |     |           |                  |     |
|----------------|-----|-----------|------------------|-----|
| 制图             | 陈迪望 | 2021.9.20 | 上溜槽溜嘴法兰          | 比例: |
| 校核             |     |           |                  | 材质: |
| 黄石晟祥铜业有限公司-制造部 |     |           | 图纸编号: 482240-255 |     |